

Microseismic criteria for rockbursts hazard assessment

Gloria Senfaute, C. Chambon, Pascal Bigarre, Yves Guise, Jean-Pierre Josien

► **To cite this version:**

Gloria Senfaute, C. Chambon, Pascal Bigarre, Yves Guise, Jean-Pierre Josien. Microseismic criteria for rockbursts hazard assessment. North American Rock Mechanics Symposium, Jun 1996, Montréal, Canada. ineris-00971963

HAL Id: ineris-00971963

<https://hal-ineris.archives-ouvertes.fr/ineris-00971963>

Submitted on 3 Apr 2014

HAL is a multi-disciplinary open access archive for the deposit and dissemination of scientific research documents, whether they are published or not. The documents may come from teaching and research institutions in France or abroad, or from public or private research centers.

L'archive ouverte pluridisciplinaire **HAL**, est destinée au dépôt et à la diffusion de documents scientifiques de niveau recherche, publiés ou non, émanant des établissements d'enseignement et de recherche français ou étrangers, des laboratoires publics ou privés.

MICROSEISMIC CRITERIA FOR ROCKBURSTS HAZARD ASSESSMENT

G. Senfaute¹, C. Chambon², P. Bigarré¹, Y. Guise³,
J.P. Josien¹

1. *INERIS - Laboratoire de Mécanique de Terrains (Ecole des Mines de Nancy)
54042 Nancy, France*
2. *Ecole des Mines de Nancy - 54042 Nancy, France.*
3. *Houillères de Bassin du Centre et du Midi, B.P. 534, 42007 St-Etienne, France*

Summary

Within the Provence operation Unit (France), microseismic remote monitoring is integrated within a research strategy bearing on areas submitted to dynamic phenomena risks. The purpose of this study is to characterise and analyse the induced microseismic activity during the operation of deep sites, in order to obtain identification criteria for the zones likely to generate such phenomena. The detailed study of the space distribution of microseismic focuses enables consistent correlations to be demonstrated between the localization of the focuses, the changes in the state of stresses in the massif during the mining operation and the configuration of exploitation. The results have opened interesting perspectives into the analysis of pressure rockburst risks, by microseismic listening.

1. Introduction

The Gardanne (France) lignite deposit is located in the Centre and South of France Basin Coal mines. It is a sub-horizontal deposit, corresponding to a basin defined by the Maastrichtian phase. The exploited coal layer offers a thickness of 2 to 3 metres depending on the sectors. The wall and hanging wall, over a thickness of 250 meters, are of limestone nature. The rest of the underlying series is formed with clay marls and

limestones. The operation is carried out according to the longwall caving method, currently at a depth of approximately 1,200 metres. In the last few years, with the increasing depth of the site, various rockbursts occurred in the operation.

The particular susceptibility of the deposit to dynamic instability phenomena dictated the development of a number of studies in order to better comprehend the occurrence mechanism of these phenomena and therefore limit their effects, whilst forecasting the phenomena whenever possible. In this scope of work, a seismic listening network was implemented at the Provence Operation Unit. Since then, significant improvements were achieved thanks to this seismic network. They enable the microseismic activity recorded in the daily reports to be integrated and associated with data drawn from site operation feedback, therefore facilitating safety-related decision-making by the operators.

2. Description of the seismic chain

2.1 Data acquisition channel

The seismic network is comprised of eight vertical stations of uniaxial geophone type as well as two tridirectional stations (natural frequency = 1 Hz). Three vertical stations and two tridirectional stations are laid out on the surface. Data transmission from this surface network to the central site's mainframe is by RF, whereas four stations installed at the working stall are wired to the central site's mainframe (figure 1).

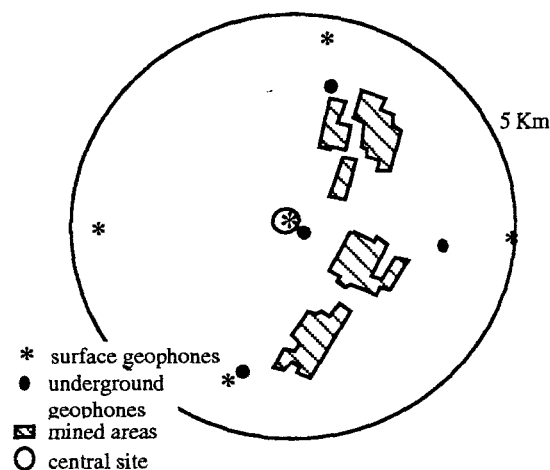

Figure 1: Geometry of the local Provence U.E. seismic network

The central acquisition system is comprised of two PC compatible microcomputers connected in parallel. The PCs are used for alternate data acquisition according to a master/slave logic, at a sampling frequency of 155 Hz. The triggering event is submitted to a combination of criteria being validated. The master PC then performs signal

acquisition for the set up time period and then switches to slave mode, whereas the slave PC switches to master mode (figure 2).

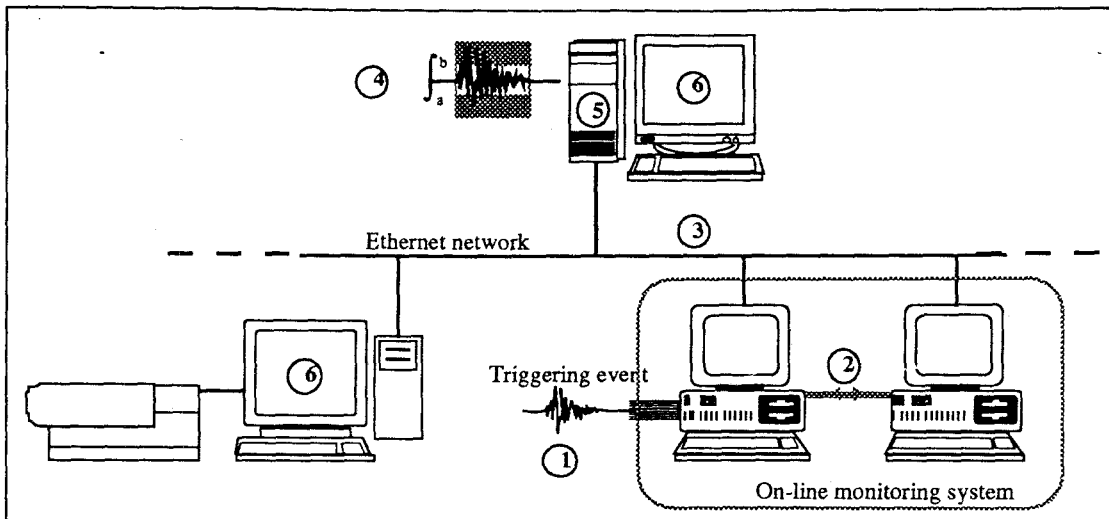

Figure 2: Seismic data acquisition and processing system. 1) event detection; 2) data acquisition on the master PC, switching of the PC to slave mode and pre-processing of the signal; 3) data transmission on multitask machine; 4) complete signal processing; 5) data storage and database type file system update; 6) interactive processing of the events in order to validate the calculated parameters.

2.2 Data processing

The automated processing run by a multitask machine in the network enables an automated bulletin to be edited for each event. The automated calculation of the wave arrival time is firstly based upon the neuromimetic network technology (SCOP : : automated pointing connection system) which determines a probable wave beginning presence range (Bigarré et al. 1995) and the upon the STA/LTA method (Allen, 1978) which involves a precise pointing of the wave arrival time. An interactive treatment can be chained a few moments after the automated processing of the event, in order to validate the calculated parameters. Finally, a database type file system is updated permanently in order to allow a further statistic study of the fundamental parameters which characterise the microseismic activity generated by the various operated sites.

2.3 Focus location accuracy

The location of tremors is an essential parameter in the analysis of the microseismic activity. The absolute accuracy of the hypocentre calculation depends on various criteria: the geometric configuration of the network, the knowledge of the wave propagation rates

and paths, the sampling frequency of the acquisition system as well as the pointing operation's reliability. Experience demonstrates that the knowledge of a wave propagation rate model as close as possible to the real geological world is essential in order to obtain a proper accuracy of the coordinates (X, Y, Z, T) for each event. Senfaute et al (1995) have developed a suitable wave propagation rate model for locating the focuses derived from the Gardanne area. It is a slanted multilayer model, which delivers locations with an accuracy of approximately ± 50 metres.

3. Space distribution study of microseismic events

Although all rockbursts make up seismic events, all seismic events do not degenerate into rockbursts. The intrinsic causes, if any, for such particular seismic events, are not well known and their shorten forecasts raise intricate problems. Therefore, the abrupt energy release may occur at various points with respect to the operation face front, for example:

- in the operated layer, ahead of the working face,
- backward of the operated working face,
- in the pillars located next to the operation,
- in two or more of the above places, simultaneously or almost simultaneously.

Therefore, the study on the space distribution of the seismic focuses is particularly significant in the analysis of the microseismic criteria for evaluating a hazard. A detailed study on the localization of the microseismic focuses induced by the operation of working face 07 of the Estaque district at the Provence mined is carried out in this framework.

Working face 07 at the Estaque district is located to the South of the deposit. It is north-east oriented, with an inclination of approximately 10° westwards. The study period is between October 1992 and July 1993; it concerns 720 metres of operated working face, for which a total of 2,223 microseismic events were recorded. The decision to study the space distribution of events associated with this working face was made according to the following criteria:

- this working face was operated following two different configurations, which allows the behaviour of the microseismic activity to be studied in two separate situations (figure.3);
- the operation of this working face was affected by various dynamic phenomena;

- its central position with respect to the geometry of the seismic network allows a good accuracy in the location of the focuses to be expected.

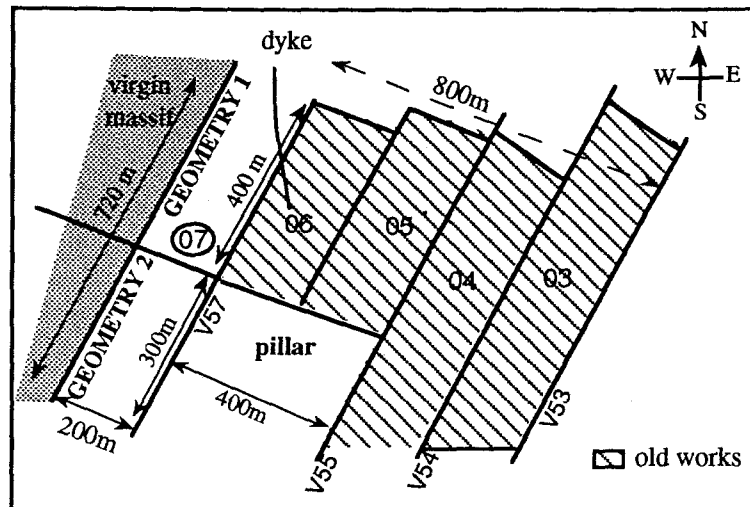

Figure 3: Schematic view of the operation configurations (geometry 1 and geometry 2) for working face 07 in the North Estaque district.

A high standard of accuracy in the wave arrival time is a prerequisite for the proper location of the focuses. For this purpose, it was necessary to process manually 2,114 seismic events, that is to say, to carry out a manual pointing of the beginning and end of the wave on 19,026 seismic signals. This processing ensures a large part of the sought accuracy in locating the focuses.

3.1 Location of the microseismic focuses with respect to the operated working face

For each event, the distance between the working face and the seismic focus was determined, as well as the location with respect to the working face, that is to say, to the rear or to the ahead of the working face. The results demonstrate that microseismic focus distribution strongly depends upon the operation geometry, namely:

- in geometry 1 (the working face runs along the old mined areas), the events are localised through the complete range of magnitudes ahead the front and behind the face, but they are more numerous to the ahead of the face, between 0 and 50 metres from the working face;

- in geometry 2 (the working face runs along a pillar) the seismic events are also localised to the rear and to the ahead of the working face, but contrarily to geometry 1, they are more numerous to the rear, between 0 and 80 metres from the working face.

These results provide a first classification of the seismic events:

- *Class A events* : a population of events located ahead of the working face. The ahead of the working face which follows the progress of the work is an area of high dynamic stresses. The load application and the fracturing of the ahead of the working face would be the generating cause for these events.

- *Class B events*: a population of events located between 0 and 80 metres to the rear of the working face. Several events, amongst which the caving-in of the back face as well as the particular operation configuration would account for the occurrence of these events.

These results outline a correct consistency between the location of the microseismic focuses and the changes which occur in the sites in the course of operation. A quantitative study of the event distribution will enable concrete criteria to be drawn up, as regards the preferential location of the focuses.

3.2 Quantifying the microseismic focus distribution

In order to quantify the event distribution, the mined face is broken down into areas. In this break-down analysis, the working face is divided into 16 different areas (figure 4). Each area will contain the corresponding events (both in numbers and in percentages), classified by magnitude classes and geometry of exploitations. The event locations in these 16 areas will enable the preferential distribution of 2,114 microseismic events recorded during working face 07 operation to be analysed.

		axis					
		meters	>100	0 to 100	0 to -100	<-100	total
behind the face	<-50	12	43	86	112	253	
	-50 to 0	8	87	326	243	664	
	0 to 50	27	239	357	81	704	
ahead of the face	>50	25	152	229	87	493	
	total	72	521	998	523	2114	

working face - virgin massif boundary working face - old works or pillar boundary

Figure 4: Graphic illustration of working face 07 break-down into areas, in order to quantify the seismic focus distribution. The X axis, at the centre of the square, corresponds to the mined face, whereas the Y axis, at the centre, corresponds to the central axis of the working face.

Small microseismic events: magnitude < 2.0

In geometry 1 (the working face runs along the old works of an adjacent face), the microseismic events of a magnitude of less than 2.0 are localised within the operated working face and preferably to the front of the face at about 25 metres from the working face (figure 5a), whereas in geometry 2 (the working face runs along a pillar), the events are preferably localised to the rear of the working face at about 25 metres to the rear and to the outside of the operated face, that is, in the pillar area (figure 5b).

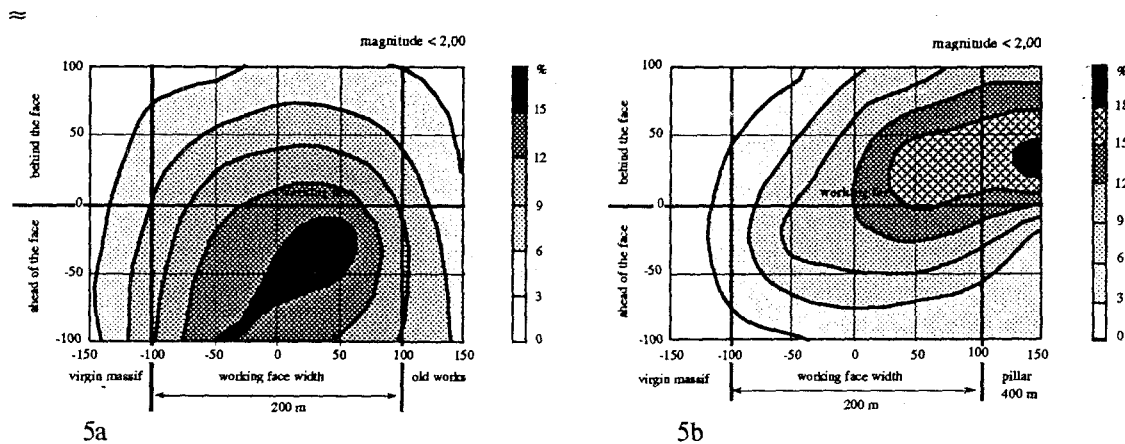

Figure 5: Preferential location of small seismic events (magnitude < 2.0) induced in the course of operation of working face 07 at the North Estaque district, according to two separate operation configurations: a. geometry 1; b. geometry 2.

The preferential distribution of this category of events highlights the bearing faces of the voids created to behind the working face. There, in geometry 2, the pillar adjacent to the operation would make up a significant bearing area due to the void in the back face. The pillars which bound the old operations make up overloaded areas. The operation working faces reaching this type of configuration area would create an overload in the areas already overloaded, which would result in microfractures which account for the occurrence of these small seismic events. In an operation adjacent to old works (geometry 1), the small events are preferably localised ahead of the working face (this would characterise the main bearing area of the voids created at the back of the face).

Strong microseismic events: magnitude ≥ 2.5

In geometry 1 (the working face runs along the old works of an adjacent face), the microseismic events are localised within the operated working face and preferably ahead of the face, between 25 and 100 metres to the front (figure 6a), whereas in geometry 2 (the working face runs along a pillar), the events are also grouped within the operated

panel and preferably to the front of the working face, between 20 and 50 metres from the face (figure 6b).

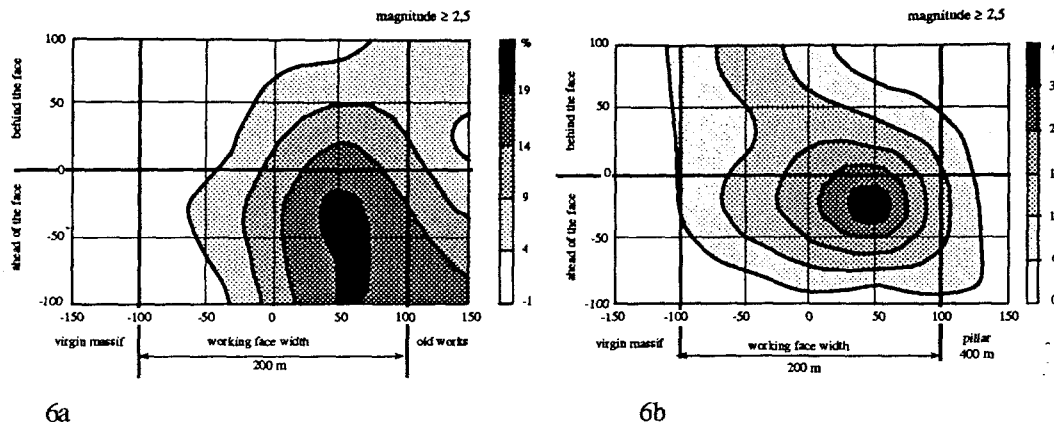

Figure 6: Preferential location of small seismic events (magnitude ≥ 2.0) induced in the course of operation of working face 07 at the North Estaque district, according to two separate operation configurations: a. geometry 1; b. geometry 2.

These strong tremors (magnitude ≥ 2.5) would be representative of the dynamic loading and fracturing at the front of the working face. Part of this category of events is also localised in the area of the old works in the adjacent face. They would be associated with the opening or slipping of former fractures revived during the operation of the new adjacent panel.

Syrek et Kijko (1988) obtained similar results in the Polish coal mines. These authors demonstrated that the most energetic events are preferably localised ahead of the mined face.

3.3 *Microseismic focus location and rockbursts*

The operation of working face 07 at the Estaque district was affected by rockburst events. These phenomena are localised in an operation configuration where the operated panel runs along the old works of an adjacent face (geometry 1, figure 6a). All these seismic events associated with damage (rockbursts) are localised next to the working face front, between 0 and 50 metres to the front and on the side of the old works in an adjacent face.

These results demonstrate that strong events (magnitude ≥ 2.5) localised next and ahead of the working face, on the side of the old works and essentially between 0 and 50 metres to the front of the working face, would be microseismic events creating a potential risk of rockbursts.

4. Conclusion

The study of the space distribution of 2,114 microseismic events highlights consistent correlations between the location of the focuses and the load application areas, in the course of operation. The results show that the operation configuration appreciably influences the preferential location of microseismic events.

In terms of the evaluation of a hazard based upon the location of the focuses, the results seem to indicate that when the focuses of strong tremors are very close to the operated working face front (essentially ahead of the face and on the side of old works in an adjacent face), a potential risk of pressure rockburst would exist. This could make up a microseismic criterion of dynamic instability hazard. The identification of this "criterion" is a major milestone and is used as guideline in the research for far more detailed criteria.

5. Bibliography

Allen V., 1978. Automatic earthquake recognition and timing from single traces. Bull Seism. Soc. Am. 68, No. 5, pp 1521 - 1532.

Ben Sliman K., Besson J.C., Mandereau G., Chambon C., 1990. "La surveillance sismique : un outil d'aide à la planification des chantiers miniers sujets aux phénomènes dynamiques" (*Seismic monitoring: a tool for planning mining sites submitted to dynamic phenomena*). 3rd Franco-Polish Symposium, Wroclaw. Studio Geotechnica et Mechanique. Vol XI No. 1 and 2, pp 55-68

Bigarré P., Lablée S., Dodo Amadou A., Piguet J.P., Josien J.P., 1995. "Utilisation de réseaux neuromimétiques pour la localisation automatique d'événements microsismiques" (*The use of neuromimetic networks in the automatic location of microseismic events*). International Congress on Rock Mechanics, Tokyo.

Gibowiez S., 1990. Keynote lecture: the mechanism of seismic events induced by mining, 2nd. Int. Symp. Rockbursts and Seismicity in Mines, ed. Fairhurst, C. Balkema, pp 3-27.

Senfaute G., Bigarré P., Josien J.P., Mathieu E., 1994. Real-time microseismic monitoring; Automatic wave processing and multilayered velocity model for accurate

event location. Rock Mechanics in Petroleum Engineering, EUROCK' 94 Delf/Netherlands, Balkema, pp. 631-638.

Senfaute G., 1995. "La surveillance microsismique de l'exploitation souterraine du charbon aux Houillères de Provence" (*Microseismic monitoring of underground coal mining at the Provence coal mines*). Thesis defended before the "Institut National Polytechnique de Lorraine" (French National General Engineering Institute of Lorraine), 321 pages.

Syrek B., Kijro C., 1988. Energy and frequency distributions of mining tremors and theirs relations to rockburst hazard in the Wujek coal mine, Poland. Acta Geophy. Pol. No. 36.