



**HAL**  
open science

## Modeling of PAH transport in soils and groundwater

Olivier Bour, Claire Rollin, Hafid Baroudi, Michel Garcia, Annelise Emonet,  
Michel A. Bues, Pierre Le Thiez, T. Blondel, Jackie Schwartz, Férid Ben  
Slimane, et al.

► **To cite this version:**

Olivier Bour, Claire Rollin, Hafid Baroudi, Michel Garcia, Annelise Emonet, et al.. Modeling of PAH transport in soils and groundwater. 8. International FZK/TNO Conference on Contaminated Soil, May 2003, Gand, Belgium. pp.803-809. ineris-00972418

**HAL Id: ineris-00972418**

**<https://hal-ineris.archives-ouvertes.fr/ineris-00972418>**

Submitted on 3 Apr 2014

**HAL** is a multi-disciplinary open access archive for the deposit and dissemination of scientific research documents, whether they are published or not. The documents may come from teaching and research institutions in France or abroad, or from public or private research centers.

L'archive ouverte pluridisciplinaire **HAL**, est destinée au dépôt et à la diffusion de documents scientifiques de niveau recherche, publiés ou non, émanant des établissements d'enseignement et de recherche français ou étrangers, des laboratoires publics ou privés.

## MODELING OF PAH TRANSPORT IN SOILS AND GROUNDWATER

O. Bour(1), C. Rollin(1), H. Baroudi(1) ; M. Garcia(2) ; A. L. Emonet(3), M. Bues(3) ; P. Le Thiez(4) ; T. Blondel(5) ; J. Schwartz(6) ; F. Benslimane(7) ; D. Guyonnet(8).

- (1) INERIS, Parc technologique Alata – B.P. 2, 60550 Verneuil-en-Halatte, France, tel : 33 3 44 55 64 96, fax : 33 3 44 55 65 56, e-mail : Olivier.bour@ineris.fr, Claire.rollin@ineris.fr, Hafid.baroudi@ineris.fr
- (2) FSS International r d, 1956, avenue Roger Salengro, 92370 Chaville, t l/fax : 33 1 47 09 09 49, <http://www.fssintl.com>,
- (3) LAboratoire Environnement, G om canique et Ouvrages, Rue du Doyen Marcel Roubault - B.P. 40, 54501 Vandoeuvre les Nancy Cedex, tel : 33 3 83 59 63 07, e-mail : Annelise.emonet@ensg.inpl-nancy.fr, Michel.Bues@ensg.inpl-nancy.fr,
- (4) IFP, 1 et 4, avenue de Bois-Pr au, 92852 Rueil-Malmaison Cedex, tel : 33 1 47 52 60 00, fax : 33 1 42 52 70 00, e-mail : pierre.le-thiez@ifp.fr,
- (5) Cabinet Conseil Blondel, Le Parc Technologique de Lyon, 12 all e Joliot Curie B t B2, 69791 Saint Priest Cedex tel : 06 61 10 96 75, e-mail : tblondel@aol.com,
- (6) ANTEA, 3 avenue C Guillemin, BP 6119, 45061 Orl ans Cedex 2, tel : 33 2 38 64 38 23, e-mail: j.schwartz@antea.brgm.fr,
- (7) ICF, 14 30 rue Alexandre, B timent C, 92635 Gennevilliers Cedex, tel : 33 1 46 88 99 14, e-mail : Ferid.benslimane@icfenvironnement.com,
- (8) BRGM, 3 avenue C Guillemin BP 6009, 45060 Orl ans Cedex 2, tel : 33 2 38 64 38 17, e-mail : d.guyonnet@brgm.fr.

## Introduction

Risk assessment for groundwater resources requires most of the time the use of numerical models. These models are used to describe the migration and the transport of pollutants and to predict the contaminant evolution. The models and their parameters selection depend on the extension and the quality of the diagnosis data. The modeller has to know the limits of application of the modelling approach to improve the quality of the assessment. The research program TRANSPOL was undertaken in order to bring a better and a common practice of the use of transport models for various groups of pollutants with similar behaviour (PAH, metals, chlorine solvents).

PAHs have a specific behaviour due to their strong affinity for the organic matter, their low solubility, and their density. These compounds are often associated with other contaminants and they are the major pollutants of disused coke plants, wood preservative treatment plants and ancient gas production plants. PAHs can also be found in the environment after major incidents or spills (fuels may indeed contain significant PAHs concentration). The particular behaviour of those compounds and their present and past uses justify to study the transport of the soluble and non-soluble phases. Naphthalene was especially studied with two complementary approaches. Naphthalene is used commonly as a tracer of pollution for the PAHs contamination due to its high solubility and its low capacity of adsorption, which increase its mobility.

Two cases have been studied. The first case (case n 1) is a real case of PAH contamination observed 40 years after the dismantling of a coke plant. Contamination is found in the soil and both in superficial and chalk aquifer. Five teams have studied the behaviour of naphthalene dissolved phase with the same input data. These teams used 5 different models to predict the naphthalene concentration in the chalk aquifer at different specified observation points. A real case of massive crude oil spill following the rupture of a pipeline has been modified (case n 2). Three teams have studied this case (cf. Table 1).

Case studied	Teams and model
Case 1 : modeling of the dissolved phase with a real data set coming from diagnosis	INERIS, MODFLOW + MT3D [1,2,3] BRGM, MISP [4,5] FSS, Visual MODFLOW + MT3D [6] ANTEA, MARTHE V5.4 [7] CNRSSP, FEFLOW 4.7
Case 2 : modeling the flow of naphthalene as a NAPL	INERIS, UTCHEM [8] LAEGO/IFP, SIMUSCOPP FSS, TOUGH2/T2VOC [9]

Table 1 : The different teams and codes used in the intercomparison process

## Modeling the behaviour of naphthalene in the dissolved phase

The coke plant was built on heterogeneous filling materials. Under these superficial layers, a superficial aquifer is present. The chalk aquifer is separated from the superficial one by a layer of clay. A geological cross section of the site is shown in Figure 1.

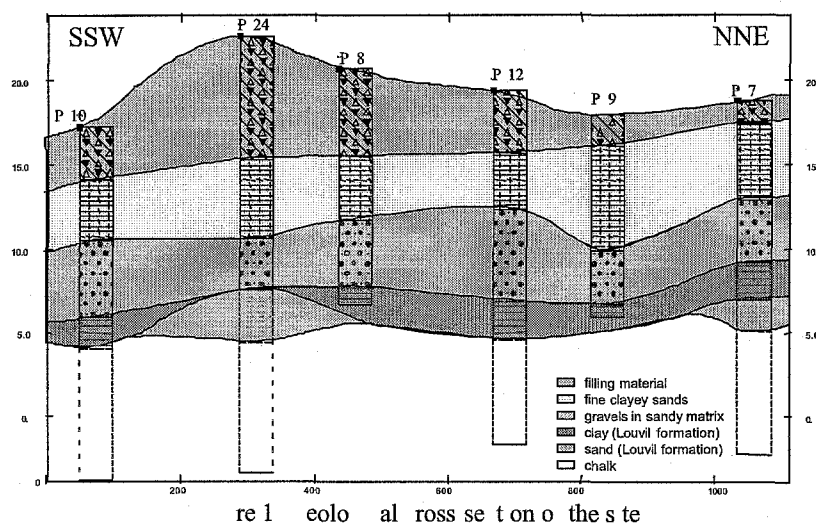

The superficial aquifer creates a dispersion and advection of the contaminant that reaches the deeper chalk aquifer. As 2 aquifers are present, modellers used multilayered models. Each team had to make assumptions and to select the proper parameters for the models. That first work was rather difficult but it corresponds to the first phase of the work of a modeling project. Due to the relatively complex geology, which was observed, the range of parameters' values, which was used, is large. The range of variation of the permeability values and partition coefficient exceeds one order of magnitude. The range of variation is lower for the surface of the source of naphthalene (cf. Table 2).

Table 2 : Range of parameter used by the 5 teams

Parameter concerning the clay	Range of variation
Permeability (m/s)	$5 \cdot 10^{-8} - 1 \cdot 10^{-9}$
Dispersivity (m)	20 - 40
Coefficient R	1,63 - 78

$$R = 1 + \frac{\rho_a K_d}{\vartheta} \quad \text{where } \rho_a \text{ is the bulk soil density, } K_d \text{ the partition coefficient and } \vartheta \text{ the total porosity of the soil.}$$

The great differences between parameters' values are the main factor explaining the range of the results obtained by the teams [10]. This range reaches more than two orders of magnitude concerning the prediction of the naphthalene concentration in well PZ10, 200 years after the dismantling of the coke plant.

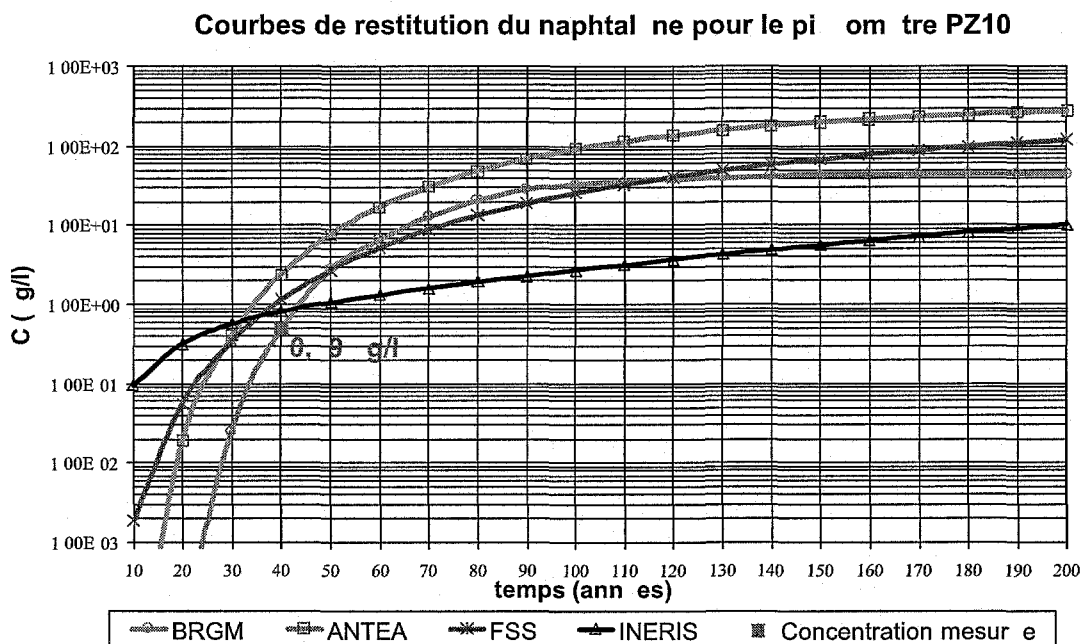

Figure 2 : Results of calculated concentration in the chalk aquifer (PZ10)

The teams have considered a source of naphthalene with a concentration equal to the solubility. The differences of the source volume is only linked to the choice of its surface. The variation of the extension of the source is lower than one order of magnitude but the locations are also different and may influence the range of variation of naphthalene concentration at a particular observation point. The flow through the clay formation is controlled by the permeability and the dispersivity of the clay. The diagnosis data allows to choose different couples of permeability and recharge which lead to the same fit with the measured water table level. A more accurate value for the permeability of the clay is needed to reduce the range of the permeability values used in the model. The retardation coefficient has also a strong effect on the calculated concentration of naphthalene. All the teams have considered a constant source of naphthalene and no biodegradation phenomena. The effect of the retardation coefficient is especially observed in the first two hundred years, before each curve reaches the maximal concentration.

### Modeling the behaviour of naphthalene in the NAPL phase

In this case (case n 2), the modified data comes from an accidental spill of crude oil (cf. Figure 3). All the parameters which describe the flow and transport model were provided to the 3 teams [11,12]. The modified data set concerns the infiltration of a volume of 105 m<sup>3</sup> of naphthalene during 6.9 days and the redistribution of the pollutant. Each team had to predict the concentration and the saturation of naphthalene at 4 observation points which are located at a distance of 50 m, 100 m, 150 et 200 m far downward from the source. In order to simplify the comparison of the results and due to the complexity of the multiphase approach, each team used approximately the same grid for the numerical simulations. The description of the main features of the three codes used in the simulation are displayed in table 3

Table 3: Main features of the numerical codes used

Numerical simulator	UTCHEM 9.0	TOUGH2/T2VOC	SIMUSCOPP
Number of dimension	3	3	3
Temporal discretisation	Implicit in pressure, explicit in concentration	Fully implicit	Specific
Spatial discretisation	Finite differences	Finite differences	Finite volumes

The dimensions of the grid are :

- Length : 307 m, 32 blocks, size of cells varying from 1.5 m to 40 m ;
- Width : 34.5 m, 9 blocks, size of cells varying from 1.5 m to 10 m ;
- Elevation : 22.5 m, 25 blocks, size of cells varying from 0.25 m to 2.5 m.

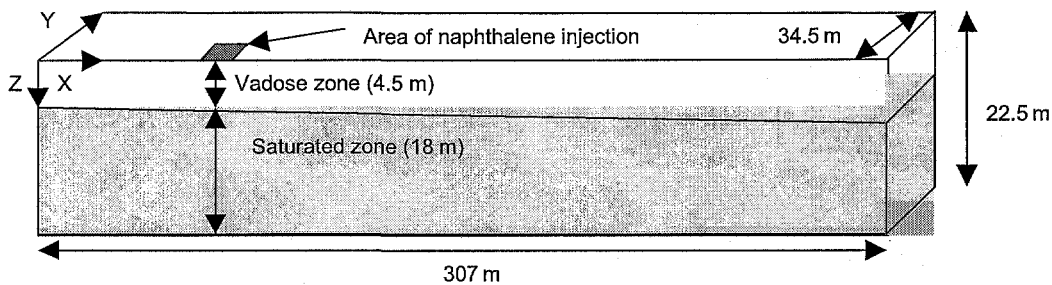

Figure 3 : Modeling domain

The average hydraulic gradient of the water table is 0.026. As the problem is symmetric, only half of the field has been modelled. The three simulators can model the multiphase flow and allow the use of van Genuchten relations [13] and Parker relations [14]. Because of the limitations of the UTCHEM interface with GMS only a diphasic problem with injection of naphthalene in the saturated zone was considered (cf. figure 4). Due to the sinking behaviour of naphthalene and to the rather weak oil residual saturation used (0.05), the difference between the volume of the injection used by the other teams is small enough (minus 15% relative error) to make these simplifications.

The evolution of the profile of saturation given by the three teams is similar. Naphthalene migrates quickly per descendum and builds a lens of pure NAPL phase on the wall of the aquifer. The volume of this lens decreases slowly and continuously with the dissolution of naphthalene. The evolution of the concentration in the aquifer is controlled by the hydraulic gradient and the distribution of the saturation of naphthalene (cf Figure 5).

The contaminant plume increases preferentially at the bottom of the aquifer where naphthalene tends to accumulate in pure NAPL phase.

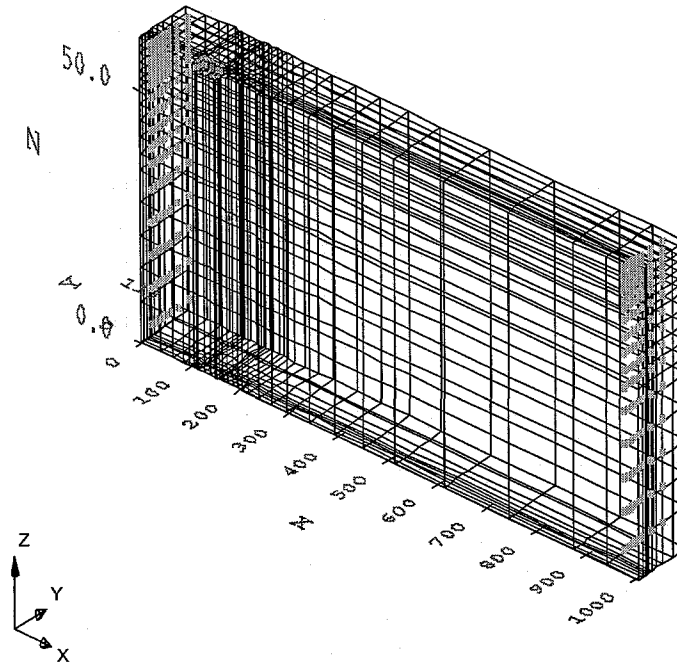

Figure 4: Grid used (measures in foot) with UTCHEM and GMS 3.1 for the modeling of a confined aquifer

The three codes are able to reproduce the particular type of DNAPL plume but the time of arrival and the concentration at the observation points may vary more or less according to the use and the different features of the numerical codes. Due to the choice of the model of an unconfined aquifer, which strictly respects the domain of modeling, two teams had to check the influence of the superposition of the regional gradient and the recharge by the rains. The coupling of the fixed upstream and downstream conditions of potential with the recharge produces a hydraulic gradient with a continuous variation which have to fit the data.

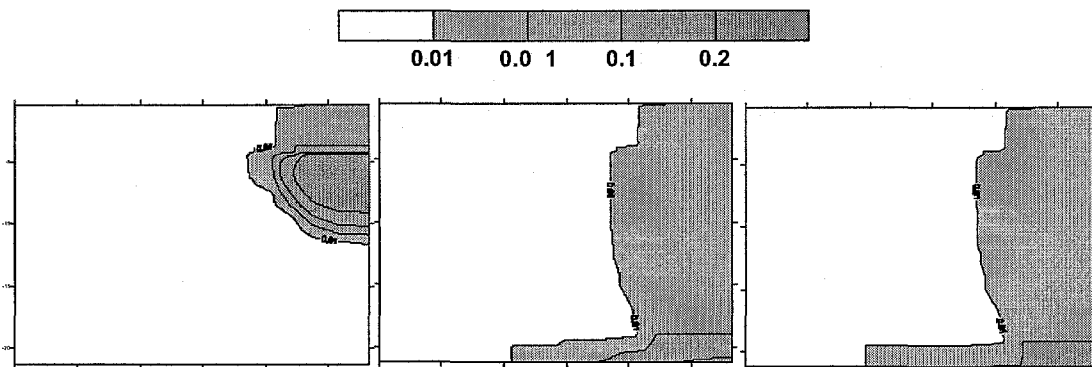

Figure 5: Profile of saturation in the Y (transversal) direction of the domain. Saturation of naphthalene at  $t = 10$  days, 2 years and 8 years. Results from SIMUSCOPP

## Conclusion

For case n 1 (real PAHs contamination) the simulation of the PAHs behaviour in the dissolved phase is strongly influenced by the choice of key parameters like the partition coefficient and the permeability of the clay. These parameters control the flow through the clay and the retardation coefficient used in the simulation of the transport of naphthalene. Other parameters could have a significant influence on the

calculated value of the naphthalene concentration. The biodegradation phenomenon has not been taken into account in this case due to the anaerobic conditions of the chalk aquifer. In this case, a more accurate diagnosis is needed in order to reduce the uncertainty of the risk assessment. A sensibility study would also have highlighted these parameters but it would not have provided the same great range of results.

The uncertainty concerning the prediction of the naphthalene concentration reaches 2 orders of magnitude with a rather complete data set. This data set concerns the analysis of 40 sample soils and more than two campaigns of analyses of 18 wells and piezometers. In this case, more measures of the clay permeability and of the partition coefficient, made afterwards, (instead of the use of the data available in the literature) have reduced the uncertainty.

For case n 2 (multiphase transport simulations), each team have reproduced the behaviour of a heavy mixture of PAHs such as creosote, which sinks to the wall of the aquifer. Due to the lack of real data for the comparison with the simulated concentrations, the first intercomparison of the results have shown the importance to reproduce the ground water velocity fields. The model used for the relative permeability is the same for the three simulators and reduces the uncertainty between the results of the teams. The behaviour of the pure DNAPL phase contrasts with the dissolved phase. In case of a massive pollution, a secondary source of pollution, more intense and durable is build during the first stage of the pollution transport. This pool of naphthalene is then available for further redistribution, mainly by spreading to form thin lenses and by dissolution.

### **Acknowledgments**

We thank the participants of the TRANSPOL program for their contributions to the research program as well as the French Ministry of the Environment and of the Sustainable Development for the financial support.

### **References**

- [1] EMSI - Groundwater modeling System GMS v2.0 Reference Manual, Department of Defense, Brigham Young University, Engineering Computer Graphics Laboratory, [www.ems-i.com](http://www.ems-i.com), Provo, Utah, USA, 482 pp, 1996.
- [2] McDonald, M. G., Harbaugh, A. W., A modular three dimensional finite-difference ground-water model (MODFLOW), U.S. Geological Survey Techniques of Water Resources Investigations, Book 6, 586 pp, 1988.
- [3] Zheng, C., MT3D : A Modular Three-Dimensional Model of Simulation of Advection, Dispersion and Chemical Reactions of Contaminants in Groundwater Systems, Report to the U.S. Protection Agency, Ada, OK, 170 pp, 1990.
- [4] Guyonnet, D., Perrochet, P., C me, B., Parriaux, A., On the hydro-dispersive equivalence between multi-layered mineral barriers. Submitted to Journal of Geotechnical and Geoenvironmental Engineering, 2000.
- [5] Wexler, E., Analytical solutions for one-, two, and three-dimensional solute transport in groundwater systems with uniform flow (CPAHer B-7). Techniques of Water Resources Investigations of the United States Geological Survey, Book 3, Application of Hydraulics, 1992.
- [6] Waterloo hydrogeologic, Visual Modflow version 2.81 user s manual,[www.flowpath.com](http://www.flowpath.com), Waterloo, Canada, 1999.
- [7] Thiery, D. Notice d utilisation du logiciel MARTHE, version 5.4, rapports BRGM R38108, R38149, 1998.

[8] Center for petroleum and geosystems engineering, technical documentation (volume II) and User's guide (volume I), the university of Texas at Austin, Austin , texas, 78712, July 2000

[9] Karten pruess, Curt Oldenburg, George Moridis, TOUGH2 User's Guide, Version 2, Ernest Orlando Lawrence Berkeley National Laboratory, Earth Science Division, November 1999

[10] Rollin C., Baroudi H., Benslimane F. – Groundwater risk assessment for a polycyclic Aromatic Hydrocarbons (PAH) contaminated site ; benchmarking and validation of numerical transport models, 2001, Water Pollution IV, Wit Press, 47-55.

[11] Panday S., Wu Y.S., Huyakorn P. S., Wade S.C., Saleem Z.A. – A composite numerical model for assessing subsurface transport for oily wastes and chemical constituents. J. Contam. Hydrol., Vol. 25, 39-62.

[12] Lebon V., Bour O. – TRANSPOL – Intercomparaison des m thodes et des mod les de migration de polluants dans les sols et les eaux. Proposition de cas-type 1(version 1.1 ) Rapport INERIS-SSE-99-21EP02/R04 du 19 avril 1999, 8 pages.

[13] Van genuchten M.Th. – A closed-form equation for predicting the hydraulic conductivity of unsaturated soils. Soil Sci. Soc. Am. J., vol 44 (1980), 892 – 898.

[14] Parker J.C., Lenhard R.J. and Kuppusamy T. – A parametric model for constitutive properties governing multiphase flow in porous media. Water Resources Research, Vol 23, N 4, 618 – 624, 198.